

WIRING THE **RCS-BELTROL ECL-6r ESC** with battery power & Phoenix PB9 sound.

N.B. It is OK to swap outputs #1, #2, #3 & #4 to suit TX sticks.

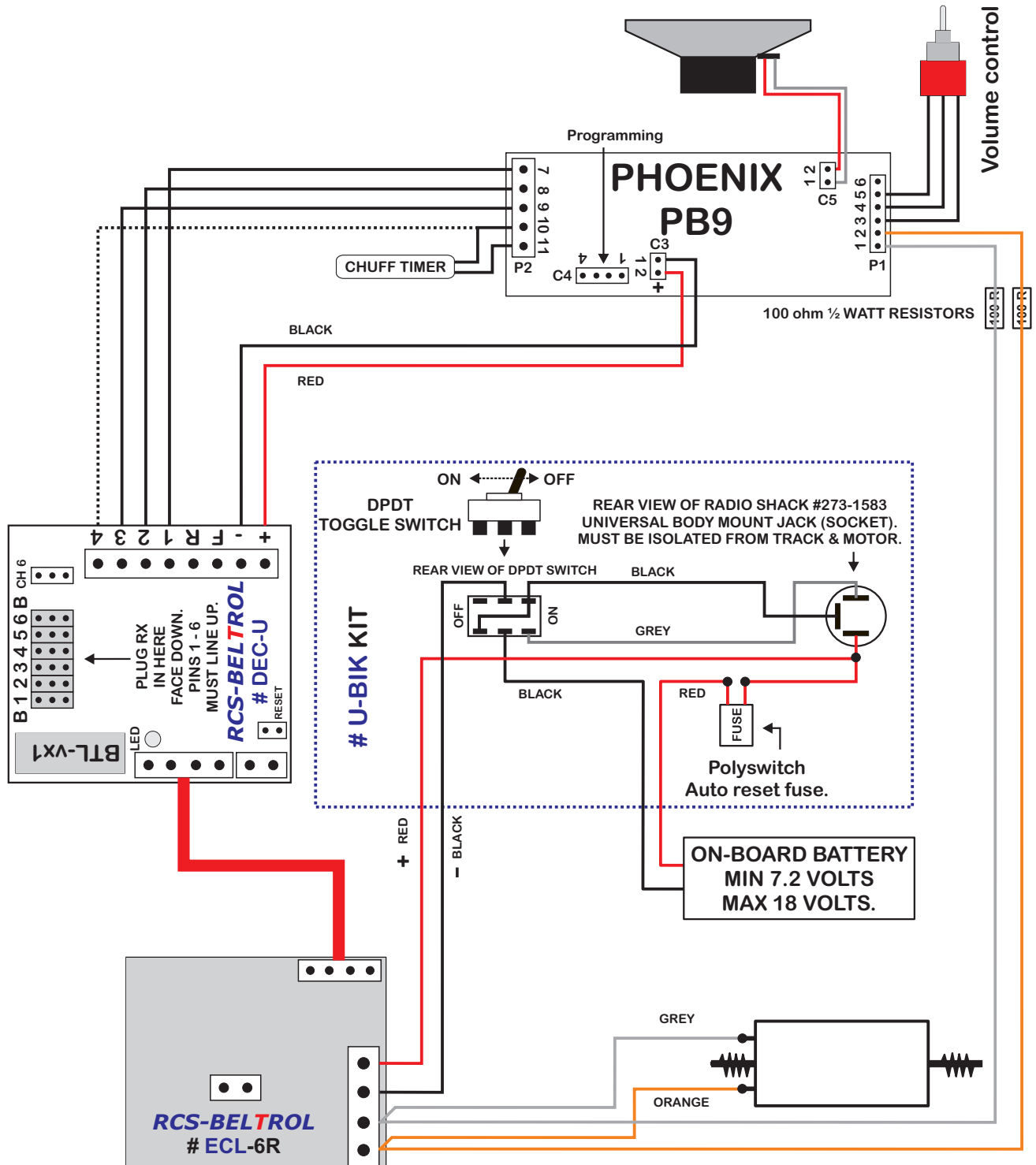

CAUTION:

SPEKTRUM® R/C & PLANET TWISTER® R/C ARE GROUP "A" SYSTEMS.
 THEY MUST USE THE **BTLvA1** PROGRAM.
 HOBBY KING® R/C & E-SKY® R/C ARE GROUP "B" SYSTEMS.
 THEY MUST USE THE **BTLvB1** PROGRAM.